

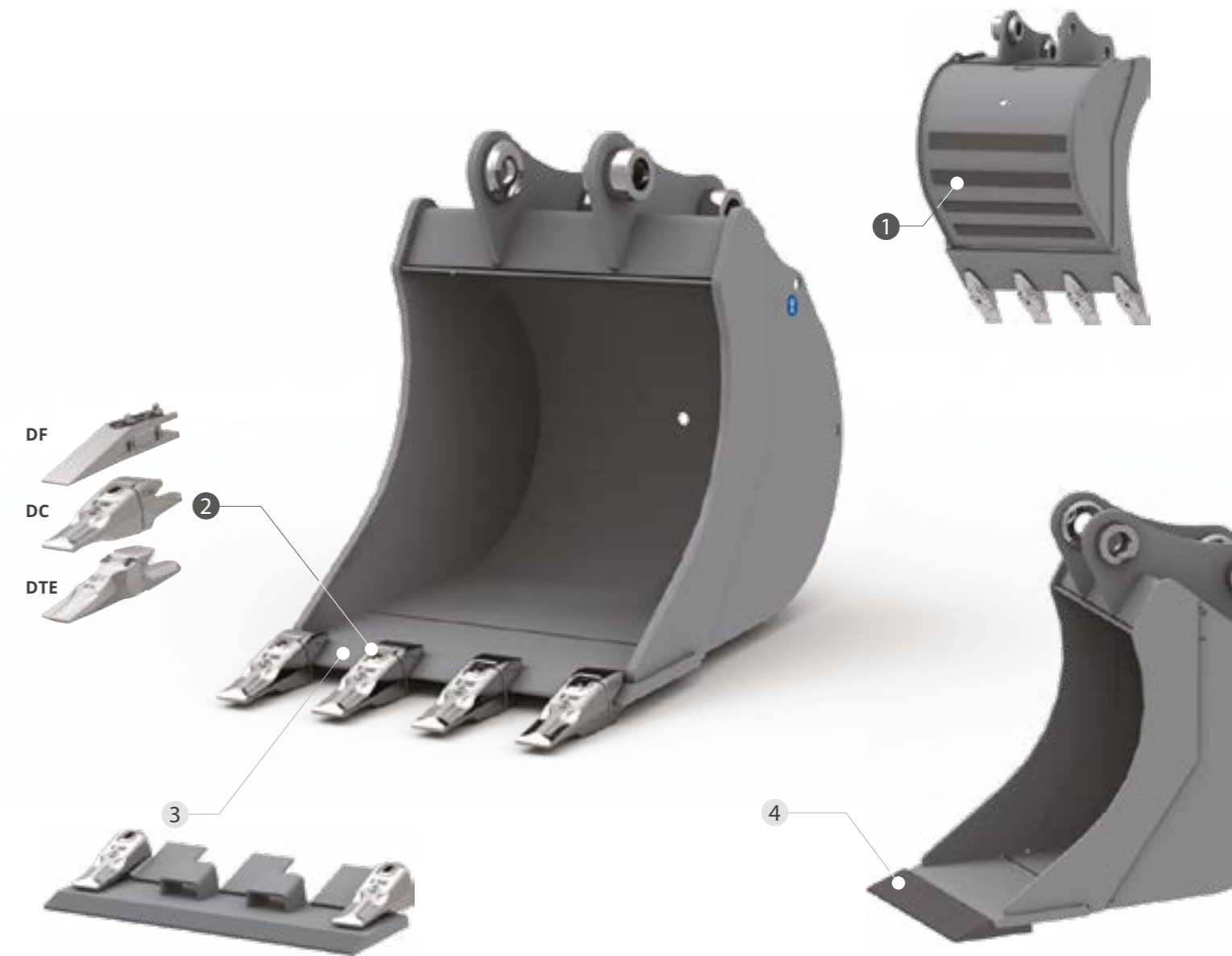

SA FORME EST CONÇUE POUR OPTIMISER LA CAPACITÉ DE PÉNÉTRATION DES TERRAINS MOYENS.



CARACTERISTIQUES TECHNIQUES STANDARD

1 BANDES DE RENFORCEMENT

LES BANDES DE RENFORCEMENT HORIZONTALES PROTÈGENT LE FOND EN AUGMENTANT SA RÉSISTANCE À L'USURE.

2 DENTS DF DENTS DC DENTS DTE

EN OPTION

3 LAME SUPPLÉMENTAIRE

INSTALLÉE SUR LE PORTE-DENTS. CETTE CONFIGURATION PERMET DES OPERATIONS D'INSTALLATION/DÉSINSTALLATION PLUS AISÉES EN ASSURANT UNE RÉSISTANCE ACCRUE AU SYSTÈME.

4 CONTRE-LAME HB500 SOUDÉE (NO DIENTES)

CONSEILLÉE POUR TRAVAILLER SUR TERRAINS ABRASIFS.

	MIDI EXCAVATOR												
MOD.	SC27	SC36	SC38	SC45	SC53	SC62	SC67	SC73	SC80	SC85	SC92 GD	SC100GD	SC110GD
TONS	0,6 - 1,2	1,2 - 1,8	1,2 - 1,8	1,8 - 2,5	2,5 - 4,0	4,0 - 5,0	5,0 - 7,5	7,5 - 10,0	10,0 - 12,0	12,0 - 14,0	12,0 - 14,0	14,0 - 18,0	18,0 - 22,0

SC27 POIDS MACHINE 0,6 - 1,2

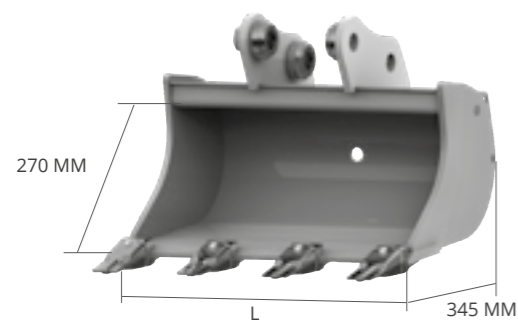

L MM	POIDS KG*	CAP. SAE L	DENTS N°	ADAPTERS
---------	--------------	---------------	-------------	----------

200	11	10	2	AF
				S - CM
				CW
250	13	14	DF2 DC3 DE3	AF
				S - CM
				CW
300	15	18	3	AF
				S - CM
				CW
350	17	21	3	AF
				S - CM
				CW
400	18	25	3	AF
				S - CM
				CW
450	20	30	3	AF
				S - CM
				CW
500	22	34	4	AF
				S - CM
				CW
600	26	42	4	AF
				S - CM
				CW
700	30	50	5	AF
				S - CM
				CW

* poids cuve sans attache

SC27 ATTACHE RAPIDE POIDS MACHINE 0,6 - 1,2

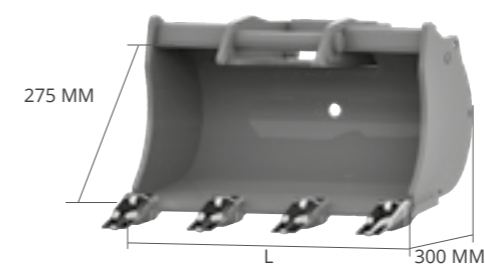
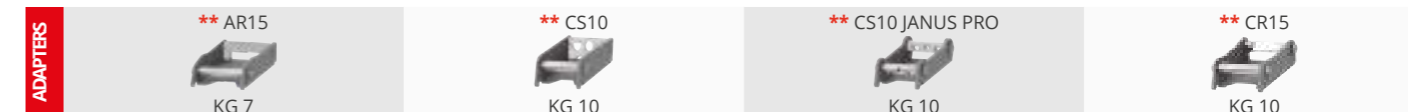

**** NB:** POSSIBLE COLLISION AVEC DISPOSITIF TIERS



EN OPTION

3	4
LAME SUPPLÉMENTAIRE	CONTRE-LAME HB500 SOUDÉE

EN OPTION

3	4
LAME SUPPLÉMENTAIRE	CONTRE-LAME HB500 SOUDÉE

L MM	POIDS KG*	CAP. SAE L	DENTS N°	ADAPTERS
---------	--------------	---------------	-------------	----------

200	11	10	2	AR - CS
				CR
				CS JANUS PRO
250	13	14	DF2 DC3 DE3	AR - CS
				CR
				CS JANUS PRO
300	15	18	3	AR - CS
				CR
				CS JANUS PRO
350	17	21	3	AR - CS
				CR
				CS JANUS PRO
400	18	25	3	AR - CS
				CR
				CS JANUS PRO
450	20	30	3	AR - CS
				CR
				CS JANUS PRO
500	22	34	4	AR - CS
				CR
				CS JANUS PRO
600	26	42	4	AR - CS
				CR
				CS JANUS PRO
700	30	50	5	AR - CS
				CR
				CS JANUS PRO

* poids cuve sans attache

SC36 POIDS MACHINE 1,2 - 1,8

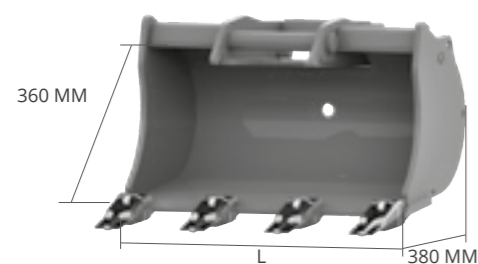
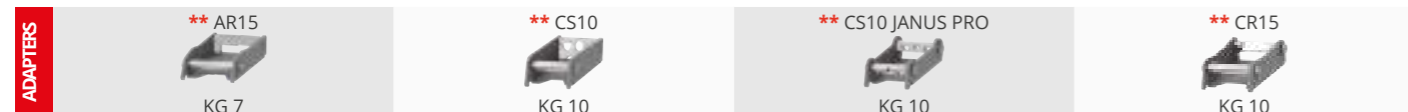

**** NB:** POSSIBLE COLLISION AVEC DISPOSITIF TIERS



EN OPTION

- ③ LAME SUPPLÉMENTAIRE
- ④ CONTRE-LAME HB500 SOUDÉE

L MM	POIDS KG*	CAP. SAE L	DENTS N°	ADAPTERS
200	15	15	2	AR - CS
				CR
				CS JANUS PRO
250	17	20	DF2 DC3 DE3	AR - CS
				CR
				CS JANUS PRO
				CS JANUS PRO
300	19	25	3	AR - CS
				CR
				CS JANUS PRO
350	21	31	3	AR - CS
				CR
				CS JANUS PRO
400	24	37	3	AR - CS
				CR
				CS JANUS PRO
450	27	43	3	AR - CS
				CR
				CS JANUS PRO
500	30	49	4	AR - CS
				CR
				CS JANUS PRO
600	34	61	4	AR - CS
				CR
				CS JANUS PRO
700	39	74	5	AR - CS
				CR
				CS JANUS PRO

* poids cuve sans attache

SC38 POIDS MACHINE 1,2 - 1,8

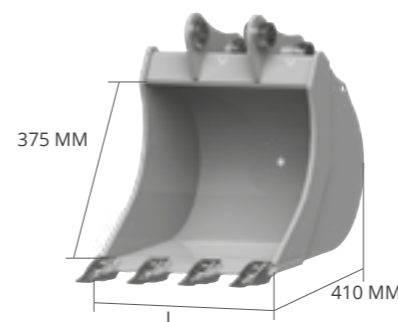

**** NB:** POSSIBLE COLLISION AVEC DISPOSITIF TIERS



EN OPTION

- ③ LAME SUPPLÉMENTAIRE
- ④ CONTRE-LAME HB500 SOUDÉE

L MM	POIDS KG*	CAP. SAE L	DENTS N°	ADAPTERS
200	15	15	2	AF - AR - CS
				CR - S - CM
				CW - CS JANUS PRO
				CW - CS JANUS PRO
250	17	20	DF2 DC3 DE3	AF - AR - CS
				CR - S - CM
				CW - CS JANUS PRO
				CW - CS JANUS PRO
300	19	25	3	AF - AR - CS
				CR - S - CM
				CW - CS JANUS PRO
				CW - CS JANUS PRO
350	21	31	3	AF - AR - CS
				CR - S - CM
				CW - CS JANUS PRO
				CW - CS JANUS PRO
400	24	37	3	AF - AR - CS
				CR - S - CM
				CW - CS JANUS PRO
				CW - CS JANUS PRO
450	27	43	3	AF - AR - CS
				CR - S - CM
				CW - CS JANUS PRO
				CW - CS JANUS PRO
500	30	49	4	AF - AR - CS
				CR - S - CM
				CW - CS JANUS PRO
				CW - CS JANUS PRO
600	34	61	4	AF - AR - CS
				CR - S - CM
				CW - CS JANUS PRO
				CW - CS JANUS PRO
700	39	74	5	AF - AR - CS
				CR - S - CM
				CW - CS JANUS PRO
				CW - CS JANUS PRO

* poids cuve sans attache

SC45 POIDS MACHINE 1,8 - 2,5

ADAPTERS	** AR30	** CS10	** CS30	** CS10 JANUS PRO	** CS30 JANUS PRO	** CR30	** CM30	** S30-150	** S30-180	CW05
	KG 10	KG 10	KG 18	KG 10	KG 19	KG 13	KG 12	KG 6	KG 8	KG 9

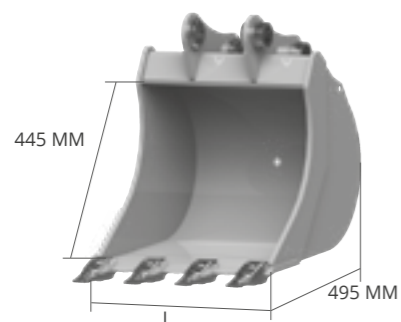

**** NB:** POSSIBLE COLLISION AVEC DISPOSITIF TIERS



EN OPTION

3	4
LAME SUPPLÉMENTAIRE	CONTRE-LAME HB500 SOUDÉE

L MM	POIDS KG*	CAP. SAE L	DENTS N°	ADAPTERS
250	23	25	2	AF - AR - CS CR - S - CM CW - CS JANUS PRO
300	26	33	3	AF - AR - CS CR - S - CM CW - CS JANUS PRO
350	29	40	3	AF - AR - CS CR - S - CM CW - CS JANUS PRO
400	32	48	3	AF - AR - CS CR - S - CM CW - CS JANUS PRO
450	35	56	3	AF - AR - CS CR - S - CM CW - CS JANUS PRO
500	38	65	4	AF - AR - CS CR - S - CM CW - CS JANUS PRO
600	44	82	4	AF - AR - CS CR - S - CM CW - CS JANUS PRO
700	50	100	5	AF - AR - CS CR - S - CM CW - CS JANUS PRO
800	58	117	5	AF - AR - CS CR - S - CM CW - CS JANUS PRO

* poids cuve sans attache

SC53 POIDS MACHINE 2,5 - 4,0

ADAPTERS	** AR40	** CS30	** CS30 JANUS PRO	** CR40	** CM30	** S40-200	** S40-240	CW05
	KG 11	KG 18	KG 19	KG 14	KG 12	KG 15	KG 17	KG 9

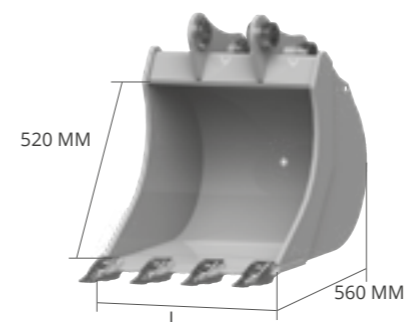

**** NB:** POSSIBLE COLLISION AVEC DISPOSITIF TIERS



EN OPTION

3	4
LAME SUPPLÉMENTAIRE	CONTRE-LAME HB500 SOUDÉE

L MM	POIDS KG*	CAP. SAE L	DENTS N°	ADAPTERS
250	32	32	2	AF - AR - CS CR - S - CM CW - CS JANUS PRO
300	35	41	3	AF - AR - CS CR - S - CM CW - CS JANUS PRO
350	40	51	3	AF - AR - CS CR - S - CM CW - CS JANUS PRO
400	44	61	3	AF - AR - CS CR - S - CM CW - CS JANUS PRO
450	48	72	3	AF - AR - CS CR - S - CM CW - CS JANUS PRO
500	51	82	4	AF - AR - CS CR - S - CM CW - CS JANUS PRO
600	59	105	4	AF - AR - CS CR - S - CM CW - CS JANUS PRO
700	67	127	5	AF - AR - CS CR - S - CM CW - CS JANUS PRO
800	75	152	5	AF - AR - CS CR - S - CM CW - CS JANUS PRO
900	83	175	5	AF - AR - CS CR - S - CM CW - CS JANUS PRO

* poids cuve sans attache

SC62 POIDS MACHINE 4,0 - 5,0

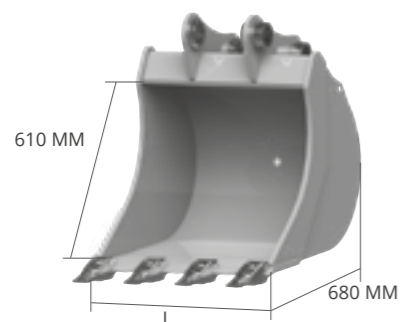

****NB:** POSSIBLE COLLISION AVEC DISPOSITIF TIERS



EN OPTION

- ③ LAME SUPPLÉMENTAIRE
- ④ CONTRE-LAME HB500 SOUDÉE

L MM	POIDS KG*	CAP. SAE L	DENTS N°	ADAPTERS
250	48	45	2	AF - AR - CS
				CR - S - CM
				CW - CS JANUS PRO
300	53	58	3	AF - AR - CS
				CR - S - CM
				CW - CS JANUS PRO
350	58	71	3	AF - AR - CS
				CR - S - CM
				CW - CS JANUS PRO
400	63	85	3	AF - AR - CS
				CR - S - CM
				CW - CS JANUS PRO
450	68	100	3	AF - AR - CS
				CR - S - CM
				CW - CS JANUS PRO
500	73	115	4	AF - AR - CS
				CR - S - CM
				CW - CS JANUS PRO
600	84	147	4	AF - AR - CS
				CR - S - CM
				CW - CS JANUS PRO
700	95	180	5	AF - AR - CS
				CR - S - CM
				CW - CS JANUS PRO
800	106	213	5	AF - AR - CS
				CR - S - CM
				CW - CS JANUS PRO
900	117	248	6	AF - AR - CS
				CR - S - CM
				CW - CS JANUS PRO
1000	128	282	6	AF - AR - CS
				CR - S - CM
				CW - CS JANUS PRO

* poids cuve sans attache

SC67 POIDS MACHINE 5,0 - 7,5

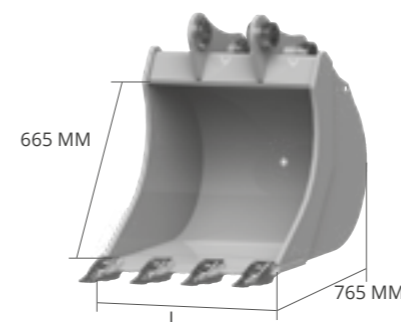

****NB:** POSSIBLE COLLISION AVEC DISPOSITIF TIERS



EN OPTION

- ③ LAME SUPPLÉMENTAIRE
- ④ CONTRE-LAME HB500 SOUDÉE

L MM	POIDS KG*	CAP. SAE L	DENTS N°	ADAPTERS
300	70	68	3	AF - AR - CS
				CR - S - CM
				CW - CS JANUS PRO
350	78	84	3	AF - AR - CS
				CR - S - CM
				CW - CS JANUS PRO
400	85	101	3	AF - AR - CS
				CR - S - CM
				CW - CS JANUS PRO
450	92	118	3	AF - AR - CS
				CR - S - CM
				CW - CS JANUS PRO
500	99	137	4	AF - AR - CS
				CR - S - CM
				CW - CS JANUS PRO
600	114	174	4	AF - AR - CS
				CR - S - CM
				CW - CS JANUS PRO
700	128	214	5	AF - AR - CS
				CR - S - CM
				CW - CS JANUS PRO
800	142	254	5	AF - AR - CS
				CR - S - CM
				CW - CS JANUS PRO
900	156	295	6	AF - AR - CS
				CR - S - CM
				CW - CS JANUS PRO
1000	170	338	6	AF - AR - CS
				CR - S - CM
				CW - CS JANUS PRO

* poids cuve sans attache

SC73 POIDS MACHINE 7,5 - 10,0

ADAPTERS	** CS80	** CS80 JANUS PRO	** CR70	** CM100	** S45	** S50	CW10
	KG 44	KG 46	KG 34	KG 35	KG 28	KG 29	KG 23

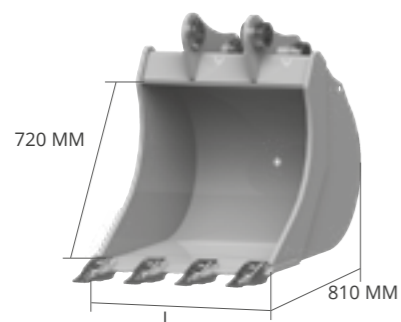

**** NB:** POSSIBLE COLLISION AVEC DISPOSITIF TIERS



EN OPTION

3	4
LAME SUPPLÉMENTAIRE	CONTRE-LAME HB500 SOUDÉE

L	POIDS	CAP. SAE	DENTS	ADAPTERS
MM	KG*	L	N°	

300	82	76	2	AF - CS
				CR - S - CM
				CW - CS JANUS PRO
350	89	94	3	AF - CS
				CR - S - CM
				CW - CS JANUS PRO
400	94	113	3	AF - CS
				CR - S - CM
				CW - CS JANUS PRO
450	103	133	3	AF - CS
				CR - S - CM
				CW - CS JANUS PRO
500	111	153	3	AF - CS
				CR - S - CM
				CW - CS JANUS PRO
600	127	196	4	AF - CS
				CR - S - CM
				CW - CS JANUS PRO
700	143	240	4	AF - CS
				CR - S - CM
				CW - CS JANUS PRO
800	159	286	5	AF - CS
				CR - S - CM
				CW - CS JANUS PRO
900	175	333	5	AF - CS
				CR - S - CM
				CW - CS JANUS PRO
1000	191	379	5	AF - CS
				CR - S - CM
				CW - CS JANUS PRO
1100	207	430	5	AF - CS
				CR - S - CM
				CW - CS JANUS PRO

* poids cuve sans attache

SC80 POIDS MACHINE 10,0 - 12,0

ADAPTERS	** CS80	** CS80 JANUS PRO	** CR70	** CM180	** S45	** S50	CW20
	KG 44	KG 46	KG 34	KG 66	KG 28	KG 29	KG 57

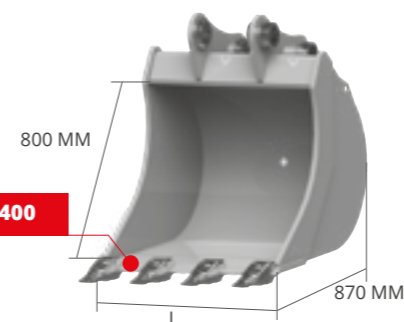

LAME EN HB400

**** NB:** POSSIBLE COLLISION AVEC DISPOSITIF TIERS



EN OPTION

3	4
LAME SUPPLÉMENTAIRE	CONTRE-LAME HB500 SOUDÉE

L	POIDS	CAP. SAE	DENTS	ADAPTERS
MM	KG*	L	N°	

300	102	86	2	AF - CS
				CR - S - CM - CS JANUS PRO
				CW
350	110	107	3	AF - CS
				CR - S - CM - CS JANUS PRO
				CW
400	121	129	3	AF - CS
				CR - S - CM - CS JANUS PRO
				CW
450	130	151	3	AF - CS
				CR - S - CM - CS JANUS PRO
				CW
500	139	174	3	AF - CS
				CR - S - CM - CS JANUS PRO
				CW
600	157	222	4	AF - CS
				CR - S - CM - CS JANUS PRO
				CW
700	175	273	4	AF - CS
				CR - S - CM - CS JANUS PRO
				CW
800	191	325	5	AF - CS
				CR - S - CM - CS JANUS PRO
				CW
900	209	379	5	AF - CS
				CR - S - CM - CS JANUS PRO
				CW
1000	226	433	5	AF - CS
				CR - S - CM - CS JANUS PRO
				CW
1100	244	486	5	AF - CS
				CR - S - CM - CS JANUS PRO
				CW
1200	262	546	6	AF - CS
				CR - S - CM - CS JANUS PRO
				CW
1300	280	602	6	AF - CS
				CR - S - CM - CS JANUS PRO
				CW

* poids cuve sans attache

SC85 MIDI POIDS MACHINE 12,0 - 14,0

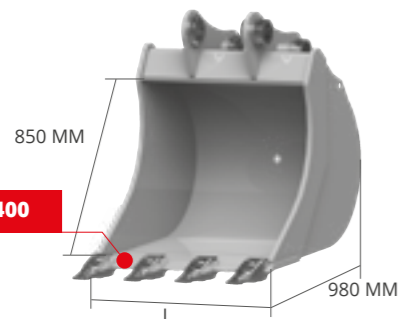

**** NB:** POSSIBLE COLLISION AVEC DISPOSITIF TIERS



EN OPTION

- ③ LAME SUPPLÉMENTAIRE
- ④ CONTRE-LAME HB500 SOUDÉE

L MM	POIDS KG*	CAP. SAE L	DENTS N°	ADAPTERS
400	170	171	3	AF - S - CM
				CS - CW
				CS JANUS PRO
500	190	235	3	AF - S - CM
				CS - CW
				CS JANUS PRO
600	210	300	4	AF - S - CM
				CS - CW
				CS JANUS PRO
700	230	368	4	AF - S - CM
				CS - CW
				CS JANUS PRO
800	250	438	5	AF - S - CM
				CS - CW
				CS JANUS PRO
900	270	510	5	AF - S - CM
				CS - CW
				CS JANUS PRO
1000	291	584	5	AF - S - CM
				CS - CW
				CS JANUS PRO
1100	312	657	5	AF - S - CM
				CS - CW
				CS JANUS PRO
1200	333	730	6	AF - S - CM
				CS - CW
				CS JANUS PRO
1300	354	810	6	AF - S - CM
				CS - CW
				CS JANUS PRO

* poids cuve sans attache

SC92 GD EXCAVATOR POIDS MACHINE 12,0 - 14,0

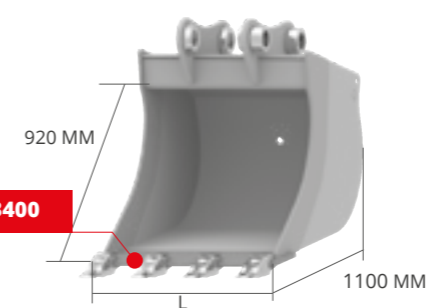

EN OPTION

- ③ LAME SUPPLÉMENTAIRE
- ④ CONTRE-LAME HB500 SOUDÉE

L MM	POIDS KG*	CAP. SAE L	DENTS N°	ADAPTERS
400	185	250	3	AF - S - CM
				CS - CW
				CS JANUS PRO
500	213	315	3	AF - S - CM
				CS - CW
				CS JANUS PRO
600	228	380	4	AF - S - CM
				CS - CW
				CS JANUS PRO
700	251	450	4	AF - S - CM
				CS - CW
				CS JANUS PRO
800	281	560	5	AF - S - CM
				CS - CW
				CS JANUS PRO
900	309	620	5	AF - S - CM
				CS - CW
				CS JANUS PRO
1000	350	700	5	AF - S - CM
				CS - CW
				CS JANUS PRO
1200	403	900	6	AF - S - CM
				CS - CW
				CS JANUS PRO

* poids cuve sans attache

SC100 GD POIDS MACHINE 14,0 - 18,0

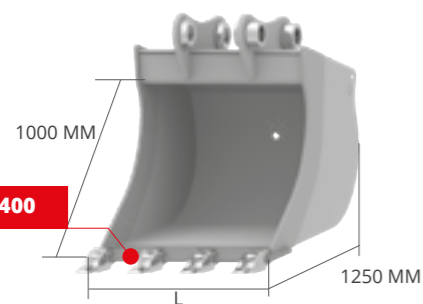

L MM POIDS KG* CAP. SAE L DENTS N° ADAPTERS

L MM	POIDS KG*	CAP. SAE L	DENTS N°	ADAPTERS
400	250	300	3	AF - S - CM
				CS - CW
				CS JANUS PRO
500	287	370	3	AF - S - CM
				CS - CW
				CS JANUS PRO
600	316	450	3	AF - S - CM
				CS - CW
				CS JANUS PRO
700	355	535	4	AF - S - CM
				CS - CW
				CS JANUS PRO
800	394	620	4	AF - S - CM
				CS - CW
				CS JANUS PRO
900	433	710	4	AF - S - CM
				CS - CW
				CS JANUS PRO
1000	472	800	5	AF - S - CM
				CS - CW
				CS JANUS PRO
1200	550	980	5	AF - S - CM
				CS - CW
				CS JANUS PRO

EN OPTION

3 LAME SUPPLÉMENTAIRE 4 CONTRE-LAME HB500 SOUDÉE

SC110 GD POIDS MACHINE 18,0 - 22,0

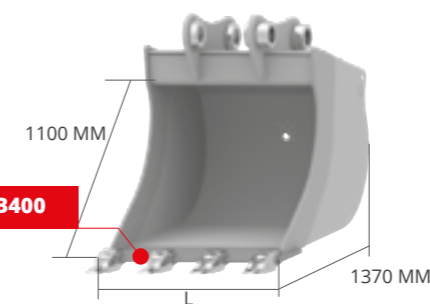

L MM POIDS KG* CAP. SAE L DENTS N° ADAPTERS

L MM	POIDS KG*	CAP. SAE L	DENTS N°	ADAPTERS
600	412	480	3	AF - S - CM
				CS - CW
				CS JANUS PRO
800	502	690	4	AF - S - CM
				CS - CW
				CS JANUS PRO
1000	592	900	5	AF - S - CM
				CS - CW
				CS JANUS PRO
1200	682	1110	5	AF - S - CM
				CS - CW
				CS JANUS PRO
1300	727	1220	6	AF - S - CM
				CS - CW
				CS JANUS PRO
1400	772	1330	6	AF - S - CM
				CS - CW
				CS JANUS PRO

EN OPTION

3 LAME SUPPLÉMENTAIRE 4 CONTRE-LAME HB500 SOUDÉE



Sur la Forêt, 16 - 5340 SOREE (Belgique)
+32/83/67.72.33
info@monfortsa.be
www.monfortsa.be



* poids cuve sans attache