



LE GODET SQUELETTE EST CONÇU POUR LA SÉLECTION DES PIERRES ET DES MATÉRIEAUX INERTES. LA DISTANCE ENTRE LES MAILLES DÉTERMINE LA TAILLE DES MATÉRIEAUX SÉLECTIONNÉS.



### CARACTERISTIQUES TECHNIQUES STANDARD

1 DENTS DC DENTS DTE

### EN OPTION

2 CONTRE-LAME HB500 SOUDÉE (NO DIENTES)  
CONSEILLÉE POUR TRAVAILLER SUR TERRAINS ABRASIFS.

MOD.	VE38	VE45	VE53	VE62	VE67	VE73	VE80	MIDI	EXCAVATOR		
								VE85	VE92 GD	VE100 GD	VE110 GD
TONS	0,6 - 1,8	1,8 - 2,5	2,5 - 4,0	4,0 - 5,0	5,0 - 7,5	7,5 - 10,0	10,0 - 12,0	12,0 - 14,0	12,0 - 14,0	14,0 - 18,0	18,0 - 22,0

## VE38 POIDS MACHINE 0,6 - 1,8

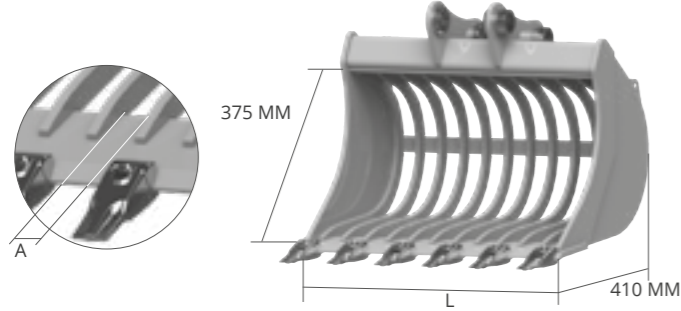

**\*\* NB:** POSSIBLE COLLISION AVEC DISPOSITIF TIERS



### EN OPTION

2  
CONTRE-LAME HB500 SOUDÉE

L MM	A MM	POIDS KG*	CAP. SAE L	DENTS N°	ADAPTERS
500	54	31	49	4	AF - AR - CS
					CR - S - CM
					CW - CS JANUS PRO
600	51	35	61	4	AF - AR - CS
					CR - S - CM
					CW - CS JANUS PRO
700	55	42	74	5	AF - AR - CS
					CR - S - CM
					CW - CS JANUS PRO

## VE45 POIDS MACHINE 1,8 - 2,5

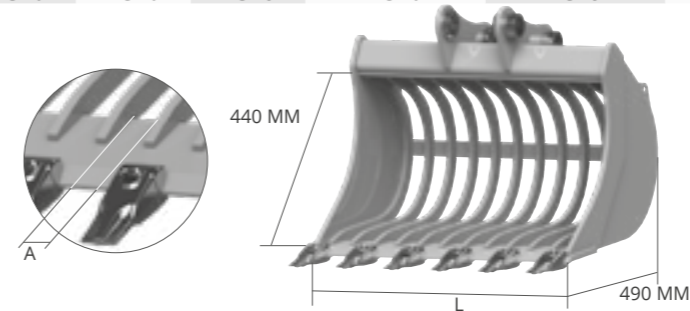
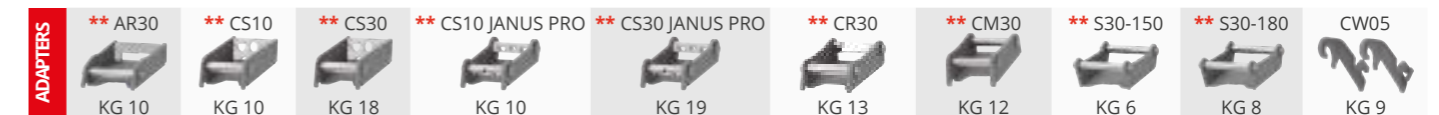

**\*\* NB:** POSSIBLE COLLISION AVEC DISPOSITIF TIERS



### EN OPTION

2  
CONTRE-LAME HB500 SOUDÉE

L MM	A MM	POIDS KG*	CAP. SAE L	DENTS N°	ADAPTERS
600	55	51	79	4	AF - AR - CS
					CR - S - CM
					CW - CS JANUS PRO
700	59	57	95	5	AF - AR - CS
					CR - S - CM
					CW - CS JANUS PRO
800	55	64	111	5	AF - AR - CS
					CR - S - CM
					CW - CS JANUS PRO

## VE53 POIDS MACHINE 2,5 - 4,0

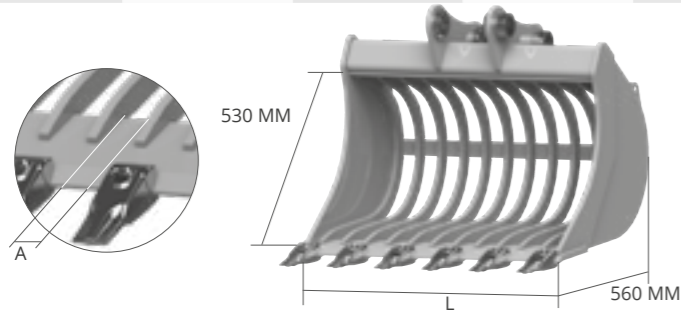
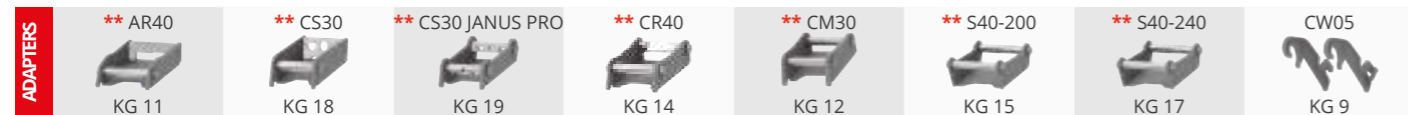

**\*\* NB:** POSSIBLE COLLISION AVEC DISPOSITIF TIERS



### EN OPTION

2  
CONTRE-LAME HB500 SOUDÉE

L MM	A MM	POIDS KG*	CAP. SAE L	DENTS N°	ADAPTERS
700	59	80	142	5	AF - AR - CS
					CR - S - CM
					CW - CS JANUS PRO
800	55	91	166	5	AF - AR - CS
					CR - S - CM
					CW - CS JANUS PRO
900	58	100	190	5	AF - AR - CS
					CR - S - CM
					CW - CS JANUS PRO

## VE62 POIDS MACHINE 4,0 - 5,0

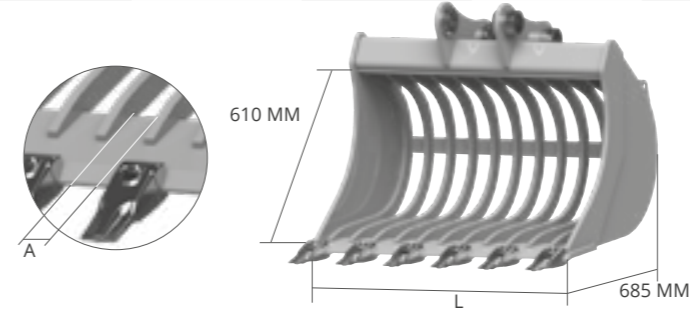

**\*\* NB:** POSSIBLE COLLISION AVEC DISPOSITIF TIERS



### EN OPTION

2  
CONTRE-LAME HB500 SOUDÉE

L MM	A MM	POIDS KG*	CAP. SAE L	DENTS N°	ADAPTERS
800	66	126	226	5	AF - AR - CS
					CR - S - CM
					CW - CS JANUS PRO
900	61	142	259	6	AF - AR - CS
					CR - S - CM
					CW - CS JANUS PRO
1000	63	153	292	6	AF - AR - CS
					CR - S - CM
					CW - CS JANUS PRO

\* poids cuve sans attache

\* poids cuve sans attache

## VE67 POIDS MACHINE 5,0 - 7,5

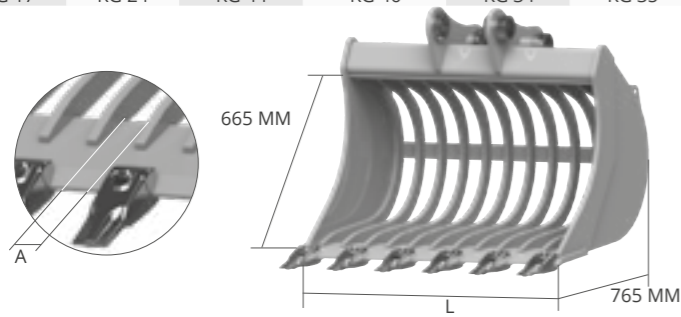

**\*\* NB:** POSSIBLE COLLISION AVEC DISPOSITIF TIERS

### EN OPTION

2  
CONTRE-LAME HB500 SOUDÉE

L MM	A MM	POIDS KG*	CAP. SAE L	DENTS N°	ADAPTERS
800	66	166	258	5	AF - AR - CS
					CR - S - CM
					CW - CS JANUS PRO
900	61	187	296	6	AF - AR - CS
					CR - S - CM
					CW - CS JANUS PRO
1000	63	202	335	6	AF - AR - CS
					CR - S - CM
					CW - CS JANUS PRO

## VE73 POIDS MACHINE 7,5 - 10,0

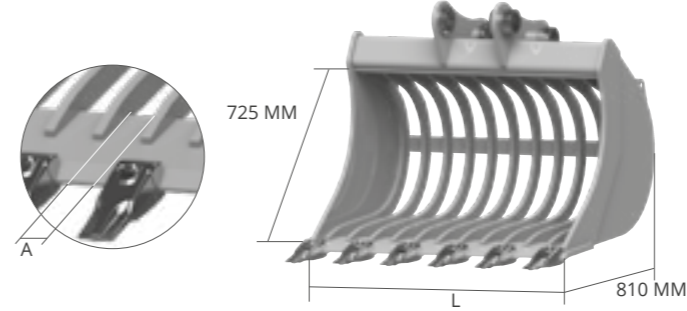

**\*\* NB:** POSSIBLE COLLISION AVEC DISPOSITIF TIERS

### EN OPTION

2  
CONTRE-LAME HB500 SOUDÉE

L MM	A MM	POIDS KG*	CAP. SAE L	DENTS N°	ADAPTERS
800	74	192	296	5	AF - CS
					CR - S - CM
					CW - CS JANUS PRO
900	67	216	340	5	AF - CS
					CR - S - CM
					CW - CS JANUS PRO
1000	69	234	384	5	AF - CS
					CR - S - CM
					CW - CS JANUS PRO

## VE80 POIDS MACHINE 10,0 - 12,0

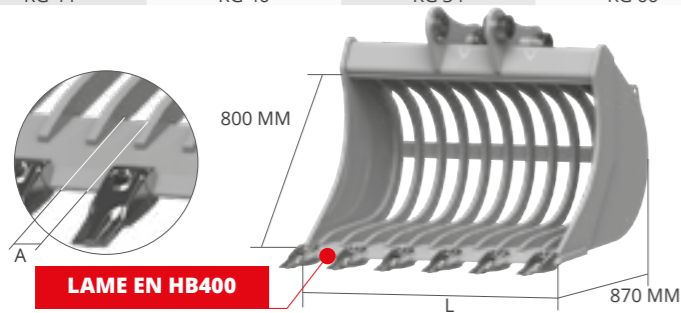

**\*\* NB:** POSSIBLE COLLISION AVEC DISPOSITIF TIERS

### EN OPTION

2  
CONTRE-LAME HB500 SOUDÉE

L MM	A MM	POIDS KG*	CAP. SAE L	DENTS N°	ADAPTERS
900	74	252	410	5	AF - CS
					CR - S - CM - CS JANUS PRO
					CW
1000	67	273	479	5	AF - CS
					CR - S - CM - CS JANUS PRO
					CW
1100	69	302	555	5	AF - CS
					CR - S - CM - CS JANUS PRO
					CW

## VE85 MIDI POIDS MACHINE 12,0 - 14,0

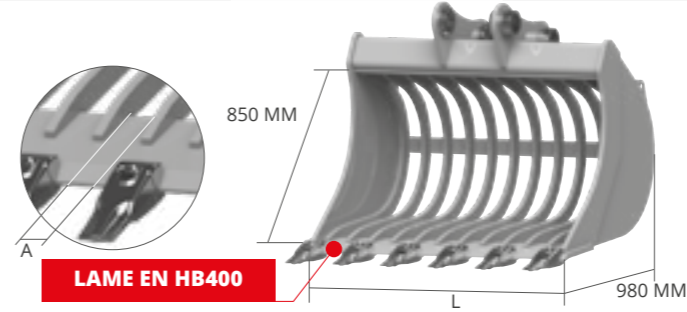

**\*\* NB:** POSSIBLE COLLISION AVEC DISPOSITIF TIERS

### EN OPTION

2  
CONTRE-LAME HB500 SOUDÉE

L MM	A MM	POIDS KG*	CAP. SAE L	DENTS N°	ADAPTERS
900	80	335	510	5	AF - S - CM
					CS - CW
					CS JANUS PRO
1000	80	363	584	5	AF - S - CM
					CS - CW
					CS JANUS PRO
1100	80	390	657	5	AF - S - CM
					CS - CW
					CS JANUS PRO
1200	80	418	730	6	AF - S - CM
					CS - CW
					CS JANUS PRO

\* poids cuve sans attache

\* poids cuve sans attache

## VE92 GD EXCAVATOR POIDS MACHINE 12,0 - 14,0

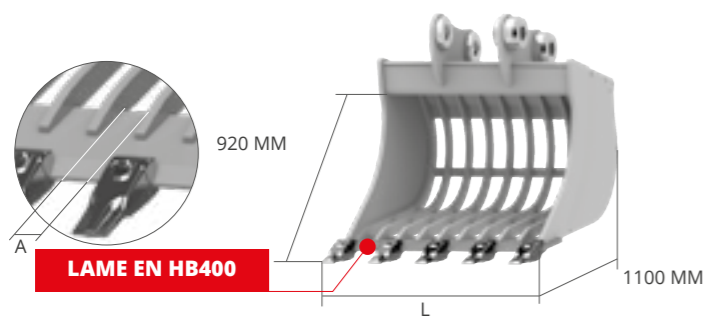

### EN OPTION

2  
CONTRE-LAME HB500 SOUDÉE

L MM	A MM	POIDS KG*	CAP. SAE L	DENTS N°	ADAPTERS
1200	80	431	783	5	AF - S - CM
					CS - CW
					CS JANUS PRO
1300	80	453	878	6	AF - S - CM
					CS - CW
					CS JANUS PRO
1400	80	475	973	6	AF - S - CM
					CS - CW
					CS JANUS PRO

## VE100 GD POIDS MACHINE 14,0 - 18,0

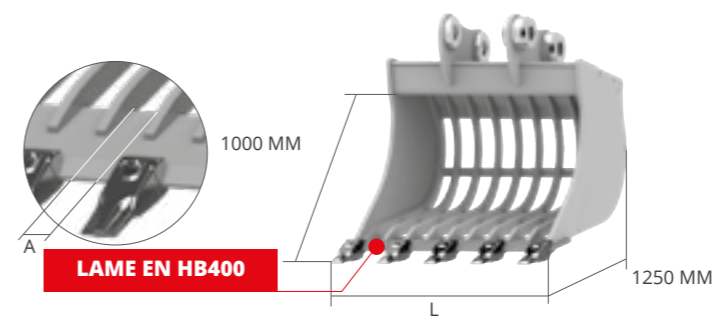

### EN OPTION

2  
CONTRE-LAME HB500 SOUDÉE

L MM	A MM	POIDS KG*	CAP. SAE L	DENTS N°	ADAPTERS
1200	100	587	909	5	AF - S - CM
					CS - CW
					CS JANUS PRO
1300	100	632	1004	6	AF - S - CM
					CS - CW
					CS JANUS PRO
1400	100	677	1108	6	AF - S - CM
					CS - CW
					CS JANUS PRO

## VE110 GD POIDS MACHINE 18,0 - 22,0

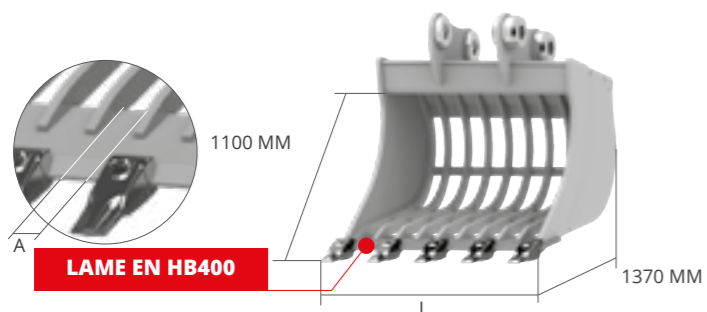

### EN OPTION

2  
CONTRE-LAME HB500 SOUDÉE

L MM	A MM	POIDS KG*	CAP. SAE L	DENTS N°	ADAPTERS
1200	100	691	1064	5	AF - S - CM
					CS - CW
					CS JANUS PRO
1300	100	741	1173	6	AF - S - CM
					CS - CW
					CS JANUS PRO
1400	100	791	1288	6	AF - S - CM
					CS - CW
					CS JANUS PRO



Sur la Forêt, 16 - 5340 SOREE (Belgique)  
+32/83/67.72.33  
info@monfortsa.be  
www.monfortsa.be



\* poids cuve sans attache

\* poids cuve sans attache