

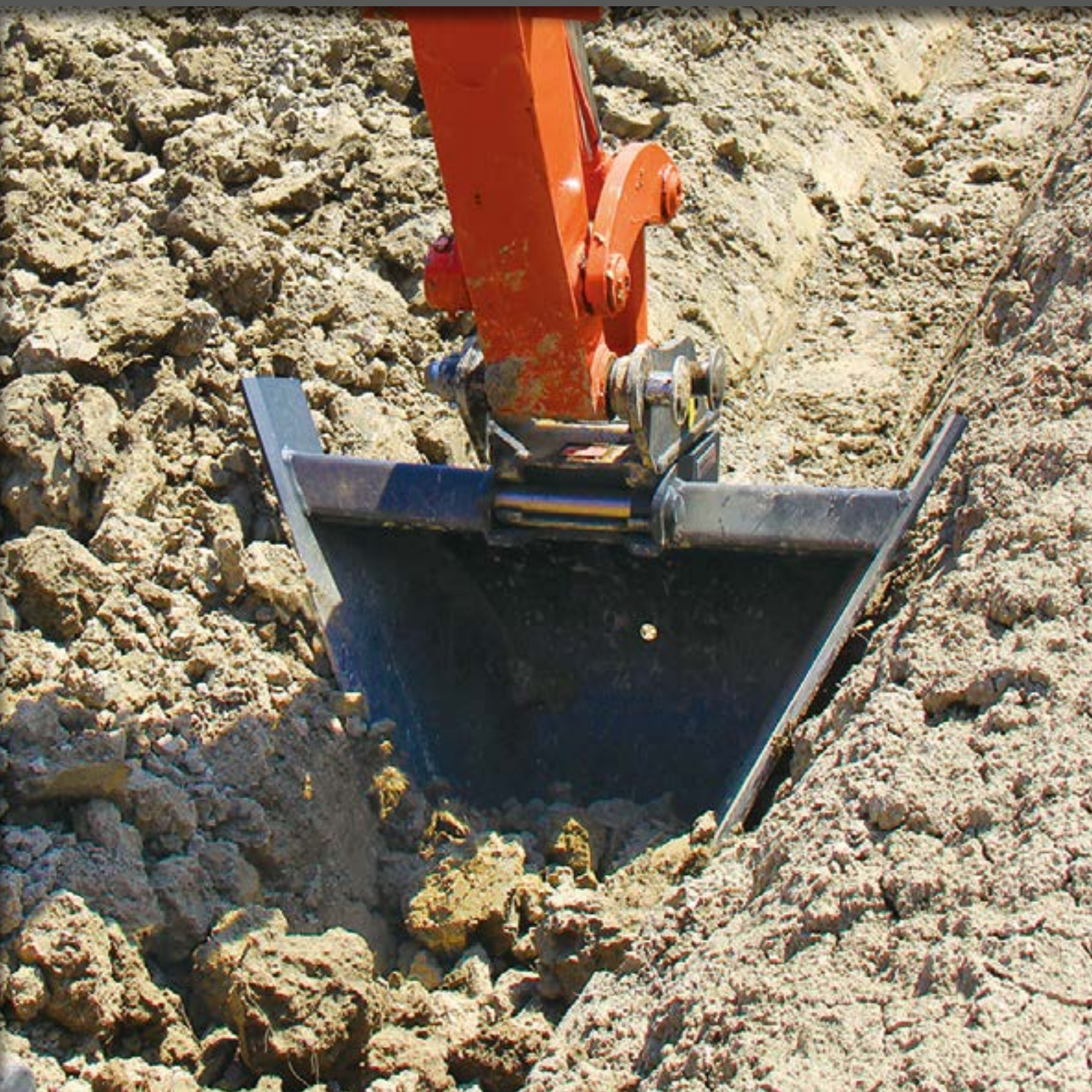

ADAPTERS

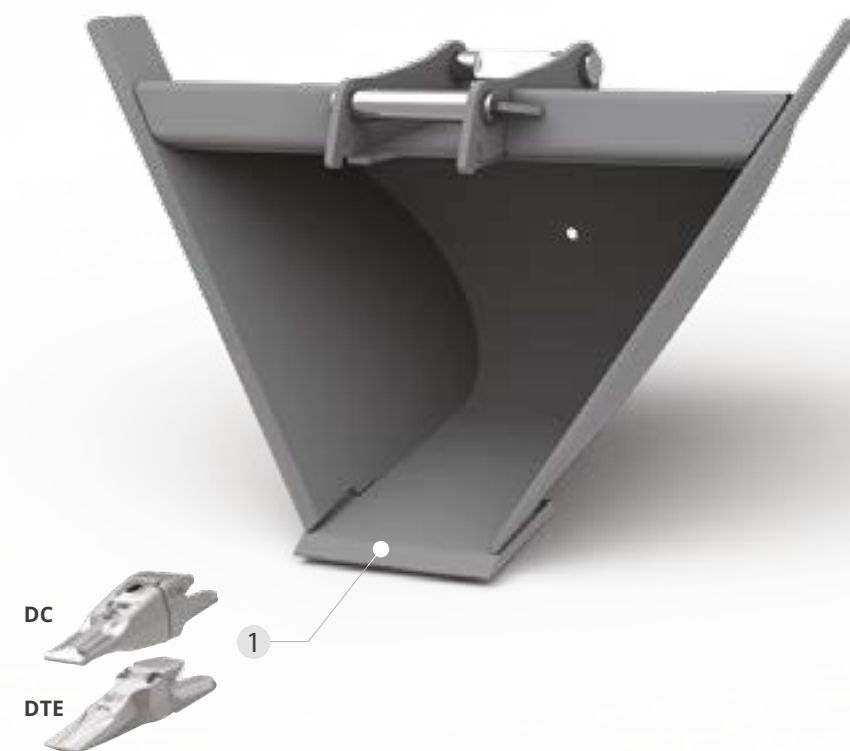

SA FORME À TRAPÈZE ET LA POSSIBILITÉ D'INCLINER LES FLANCS DE 52°-60° PERMETTENT LA RÉALISATION ET L'ENTRETIEN DES FOSSÉS ET DES CANAUX DE DIMENSIONS ET ANGLES DIVERS.



EN OPTION

- 1 **DENTS DC** **DENTS DTE**

MOD.	T38	T45	T53	T62	T67	T73	T80	MIDI		EXCAVATOR	
								T85 GD	T92 GD	T100 GD	T110 GD
TONS	0,6 - 1,8	1,8 - 2,5	2,5 - 4,0	4,0 - 5,0	5,0 - 7,5	7,5 - 10,0	10,0 - 12,0	12,0 - 14,0	12,0 - 14,0	14,0 - 18,0	18,0 - 22,0

T38 POIDS MACHINE 0,6 - 1,8

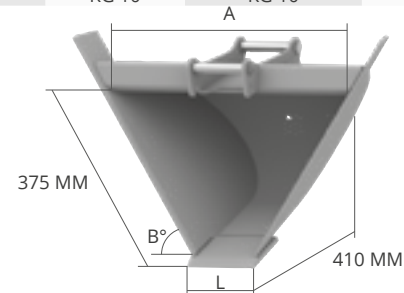

**** NB:** POSSIBLE COLLISION AVEC DISPOSITIF TIERS



EN OPTION



L MM	A MM	B°	POIDS KG*	CAP. SAE L	ADAPTERS
200	607	52°	27	47	AF - AR - CS
					CR - S - CM
					CW - CS JANUS PRO
200	490	60°	24	37	AF - AR - CS
					CR - S - CM
					CW - CS JANUS PRO

T45 POIDS MACHINE 1,8 - 2,5

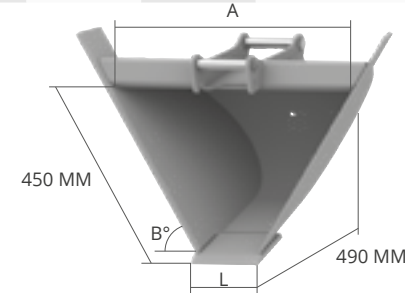

**** NB:** POSSIBLE COLLISION AVEC DISPOSITIF TIERS



EN OPTION



L MM	A MM	B°	POIDS KG*	CAP. SAE L	ADAPTERS
250	741	52°	45	77	AF - AR - CS
					CR - S - CM
					CW - CS JANUS PRO
250	600	60°	40	63	AF - AR - CS
					CR - S - CM
					CW - CS JANUS PRO

T53 POIDS MACHINE 2,5 - 4,0

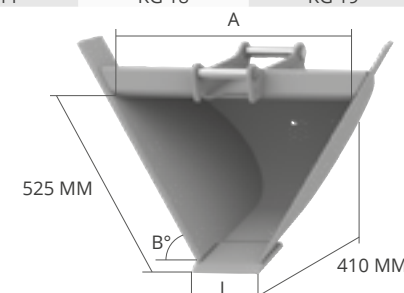

**** NB:** POSSIBLE COLLISION AVEC DISPOSITIF TIERS



EN OPTION



L MM	A MM	B°	POIDS KG*	CAP. SAE L	ADAPTERS
300	868	52°	69	140	AF - AR - CS
					CR - S - CM
					CW - CS JANUS PRO
300	705	60°	61	114	AF - AR - CS
					CR - S - CM
					CW - CS JANUS PRO

T62 POIDS MACHINE 4,0 - 5,0

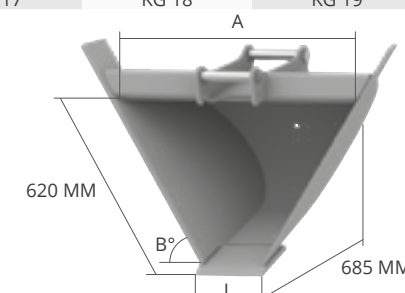

**** NB:** POSSIBLE COLLISION AVEC DISPOSITIF TIERS



EN OPTION



L MM	A MM	B°	POIDS KG*	CAP. SAE L	ADAPTERS
300	985	52°	101	190	AF - AR - CS
					CR - S - CM
					CW - CS JANUS PRO
300	790	60°	88	153	AF - AR - CS
					CR - S - CM
					CW - CS JANUS PRO

* poids cuve sans attache

* poids cuve sans attache

T67 POIDS MACHINE 5,0 - 7,5

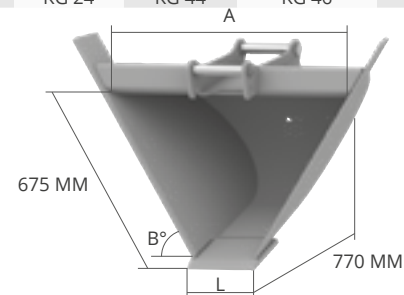
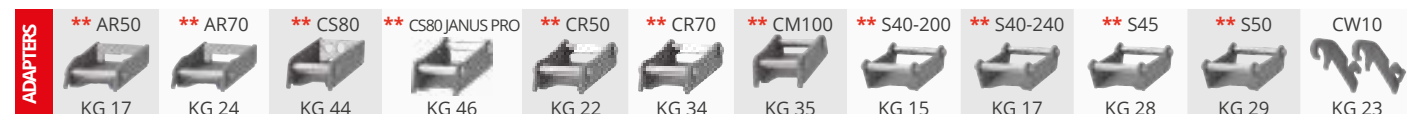

**** NB:** POSSIBLE COLLISION AVEC DISPOSITIF TIERS



EN OPTION



L MM	A MM	B°	POIDS KG*	CAP. SAE L	ADAPTERS
---------	---------	----	--------------	---------------	----------

350	1087	52°	144	239	AF - AR - CS
					CR - S - CM
					CW - CS JANUS PRO
350	876	60°	126	191	AF - AR - CS
					CR - S - CM
					CW - CS JANUS PRO

T73 POIDS MACHINE 7,5 - 10,0

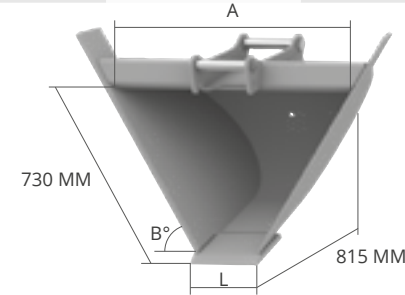

**** NB:** POSSIBLE COLLISION AVEC DISPOSITIF TIERS



EN OPTION



L MM	A MM	B°	POIDS KG*	CAP. SAE L	ADAPTERS
---------	---------	----	--------------	---------------	----------

350	1157	52°	166	318	AF - CS
					CR - S - CM
					CW - CS JANUS PRO
350	928	60°	146	254	AF - CS
					CR - S - CM
					CW - CS JANUS PRO

T80 POIDS MACHINE 10,0 - 12,0

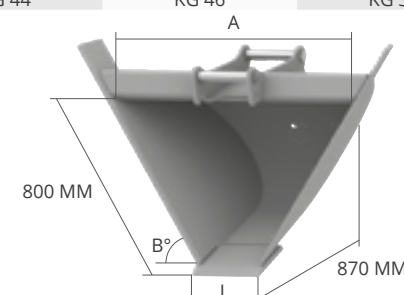

**** NB:** POSSIBLE COLLISION AVEC DISPOSITIF TIERS



EN OPTION



L MM	A MM	B°	POIDS KG*	CAP. SAE L	ADAPTERS
---------	---------	----	--------------	---------------	----------

350	1236	52°	207	355	AF - CS
					CR - S - CM - CS JANUS PRO
					CW
350	985	60°	184	281	AF - CS
					CR - S - CM - CS JANUS PRO
					CW

T85 GD MIDI POIDS MACHINE 12,0 - 14,0

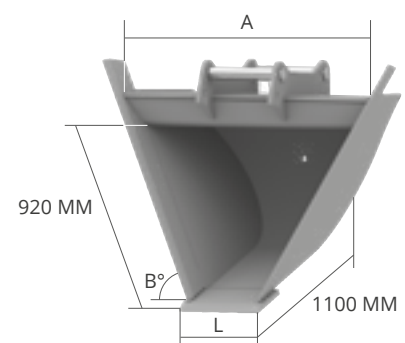

EN OPTION



L MM	A MM	B°	POIDS KG*	CAP. SAE L	ADAPTERS
---------	---------	----	--------------	---------------	----------

350	1420	52°	320	430	AF - S - CM
					CS - CW
					CS JANUS PRO
350	1120	60°	275	370	AF - S - CM
					CS - CW
					CS JANUS PRO

* poids cuve sans attache

* poids cuve sans attache

T92 GD EXCAVATOR POIDS MACHINE 12,0 - 14,0

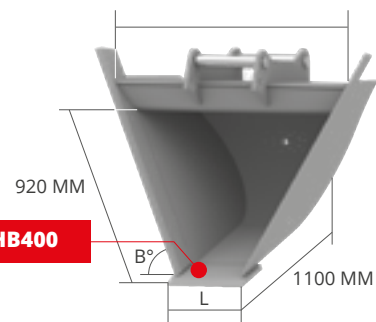

EN OPTION

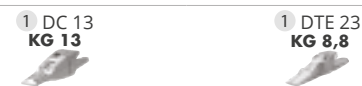

L MM	A MM	B°	POIDS KG*	CAP. SAE L	ADAPTERS
400	1550	52°	400	540	AF - S - CM CS - CW CS JANUS PRO
400	1230	60°	340	470	AF - S - CM CS - CW CS JANUS PRO

T100 GD POIDS MACHINE 14,0 - 18,0

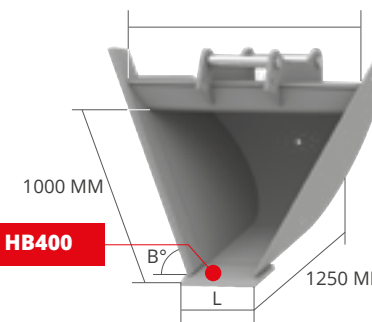

EN OPTION



L MM	A MM	B°	POIDS KG*	CAP. SAE L	ADAPTERS
400	1680	52°	530	680	AF - S - CM CS - CW CS JANUS PRO
400	1320	60°	455	585	AF - S - CM CS - CW CS JANUS PRO

T110 GD POIDS MACHINE 18,0 - 22,0

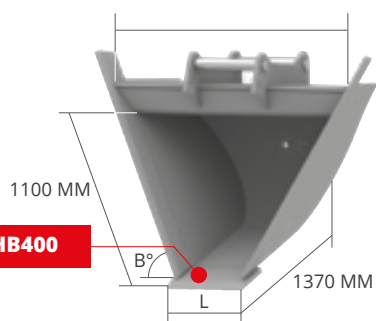

EN OPTION

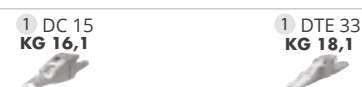

L MM	A MM	B°	POIDS KG*	CAP. SAE L	ADAPTERS
400	1820	52°	660	870	AF - S - CM CS - CW CS JANUS PRO
400	1100	60°	565	740	AF - S - CM CS - CW CS JANUS PRO



Sur la Forêt, 16 - 5340 SOREE (Belgique)
+32/83/67.72.33
info@monfortsa.be
www.monfortsa.be

