



HB400



CHARACTERISTIQUES TECHNIQUES STANDARD

- ① **PROFIL ALLONGÉ**
- ② **LAME EN HB400**

EN OPTION

- ③ **DENTS DC OU DENTS DTE**
- ④ **VERSION RÉVERSIBLE CW**
CET ADAPTEUR PERMET DE RENDRE LE GODET RÉVERSIBLE.

SA FORME ALLONGÉE EMPÊCHE QUE LE TERRAIN ADHÈRE AUX PAROIS LATÉRALES DU GODET ET FACILITE LE DECHARGEMENT DES MATÉRIAUX ARGILEUX ET MOUILLÉS. SON FOND EN MAILLES LE REND ADAPTÉ À DES TRAVAUX SOIT DE TERRASSEMENT EN SOLS TRÈS MOUILLÉS SOIT DE SÉLECTION ET RECYCLAGE DES MATÉRIAUX INERTES. LAME EN HB400.

| MOD. | VN35 | VN41 | VN52 | VN60 | VN66 | VN75 | VN85 |
|------|-----------|-----------|-----------|-----------|-----------|-----------|------------|
| TONS | 0,6 - 1,2 | 1,2 - 1,8 | 1,8 - 2,5 | 2,5 - 4,0 | 4,0 - 6,0 | 6,0 - 7,5 | 7,5 - 12,0 |

VN35 POIDS MACHINE 0,6 - 1,2

ADAPTERS

CW5
KG 9

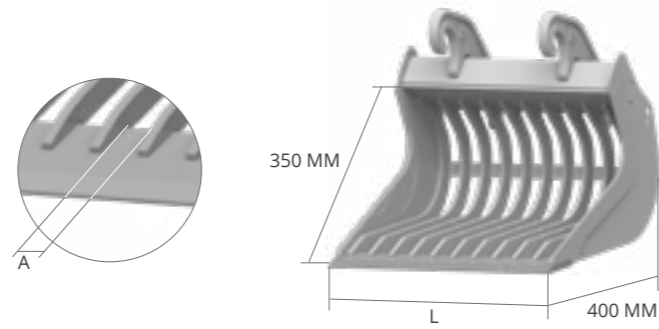

EN OPTION

| 4 | 4 | 5 |
|----------|-----------|-----------------------|
| DENTS DC | DENTS DTE | VERSION RÉVERSIBLE CW |

| L MM | A MM | POIDS KG* | CAP. SAE L | |
|---------|---------|--------------|---------------|----|
| 400 | 53 | 24 | 32 | AF |
| 400 | 53 | 24 | 32 | CW |
| 500 | 50 | 29 | 42 | AF |
| 500 | 50 | 29 | 42 | CW |
| 600 | 49 | 33 | 52 | AF |
| 600 | 49 | 33 | 52 | CW |

VN41 POIDS MACHINE 1,2 - 1,8

ADAPTERS

CW5
KG 9

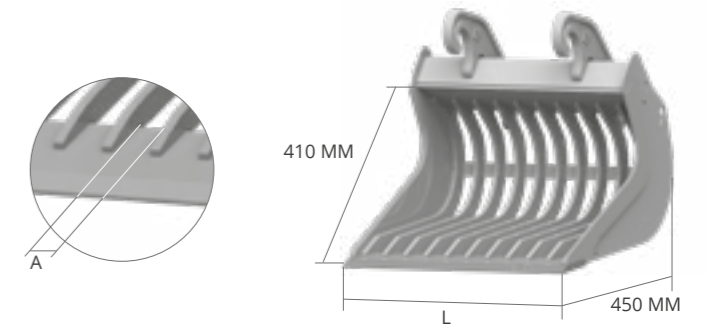

EN OPTION

| 4 | 4 | 5 |
|----------|-----------|-----------------------|
| DENTS DC | DENTS DTE | VERSION RÉVERSIBLE CW |

| L MM | A MM | POIDS KG* | CAP. SAE L | |
|---------|---------|--------------|---------------|----|
| 400 | 53 | 29 | 42 | AF |
| 400 | 53 | 29 | 42 | CW |
| 500 | 50 | 34 | 55 | AF |
| 500 | 50 | 34 | 55 | CW |
| 600 | 49 | 39 | 67 | AF |
| 600 | 49 | 39 | 67 | CW |
| 700 | 52 | 44 | 80 | AF |
| 700 | 52 | 44 | 80 | CW |

VN52 POIDS MACHINE 1,8 - 2,5

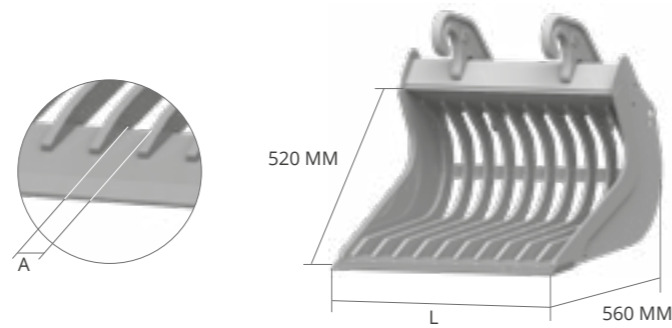

EN OPTION

| 4 | 4 | 5 |
|----------|-----------|-----------------------|
| DENTS DC | DENTS DTE | VERSION RÉVERSIBLE CW |

| L MM | A MM | POIDS KG* | CAP. SAE L | |
|---------|---------|--------------|---------------|----|
| 500 | 56 | 44 | 77 | AF |
| 500 | 56 | 44 | 77 | CW |
| 600 | 52 | 50 | 96 | AF |
| 600 | 52 | 50 | 96 | CW |
| 700 | 56 | 58 | 115 | AF |
| 700 | 56 | 58 | 115 | CW |
| 800 | 53 | 64 | 135 | AF |
| 800 | 53 | 64 | 135 | CW |

VN60 POIDS MACHINE 2,5 - 4,0

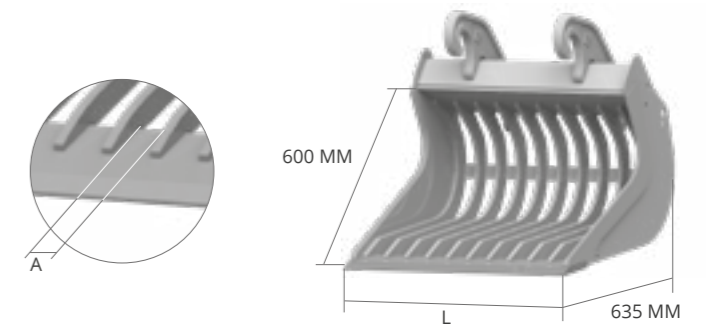

EN OPTION

| 4 | 4 | 5 |
|----------|-----------|-----------------------|
| DENTS DC | DENTS DTE | VERSION RÉVERSIBLE CW |

| L MM | A MM | POIDS KG* | CAP. SAE L | |
|---------|---------|--------------|---------------|----|
| 500 | 56 | 61 | 106 | AF |
| 500 | 56 | 61 | 106 | CW |
| 600 | 52 | 70 | 132 | AF |
| 600 | 52 | 70 | 132 | CW |
| 700 | 50 | 81 | 159 | AF |
| 700 | 50 | 81 | 159 | CW |
| 800 | 53 | 89 | 186 | AF |
| 800 | 53 | 89 | 186 | CW |
| 900 | 56 | 98 | 212 | AF |
| 900 | 56 | 98 | 212 | CW |
| 1000 | 59 | 109 | 239 | AF |
| 1000 | 59 | 109 | 239 | CW |

* poids cuve sans attache

* poids cuve sans attache

VN66 POIDS MACHINE 4,0 - 6,0

ADAPTERS

CW10
KG 23

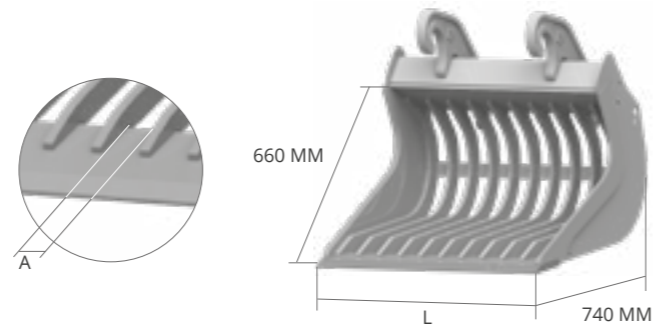

| L MM | A MM | POIDS KG* | CAP. SAE L | |
|---------|---------|--------------|---------------|-----|
| 600 | 49 | 87 | 153 | AF |
| 600 | 49 | 87 | 153 | CW |
| 700 | 53 | 97 | 185 | AF |
| 700 | 53 | 97 | 185 | CW |
| 800 | 56 | 107 | 217 | AF |
| 800 | 56 | 107 | 217 | CW |
| 900 | 59 | 116 | 250 | AFS |
| 900 | 59 | 116 | 250 | CW |
| 1000 | 61 | 129 | 282 | AF |
| 1000 | 61 | 129 | 282 | CW |

EN OPTION

| 4 | 4 | 5 |
|----------|-----------|-----------------------|
| DENTS DC | DENTS DTE | VERSION RÉVERSIBLE CW |

VN75 POIDS MACHINE 6,0 - 7,5

ADAPTERS

CW10
KG 23

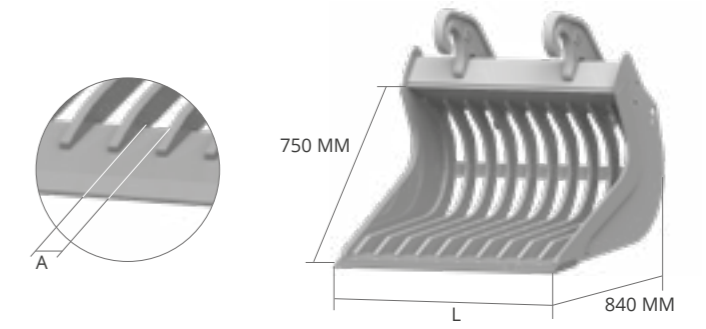

| L MM | A MM | POIDS KG* | CAP. SAE L | |
|---------|---------|--------------|---------------|----|
| 600 | 55 | 110 | 183 | AF |
| 600 | 55 | 110 | 183 | CW |
| 700 | 59 | 123 | 222 | AF |
| 700 | 59 | 123 | 222 | CW |
| 800 | 55 | 140 | 262 | AF |
| 800 | 55 | 140 | 262 | CW |
| 900 | 52 | 153 | 302 | AF |
| 900 | 52 | 153 | 302 | CW |
| 1000 | 55 | 166 | 343 | AF |
| 1000 | 55 | 166 | 343 | CW |
| 1100 | 57 | 183 | 383 | AF |
| 1100 | 57 | 183 | 383 | CW |

EN OPTION

| 4 | 4 | 5 |
|----------|-----------|-----------------------|
| DENTS DC | DENTS DTE | VERSION RÉVERSIBLE CW |

VN85 POIDS MACHINE 7,5 - 12,0

ADAPTERS

CW10
KG 23

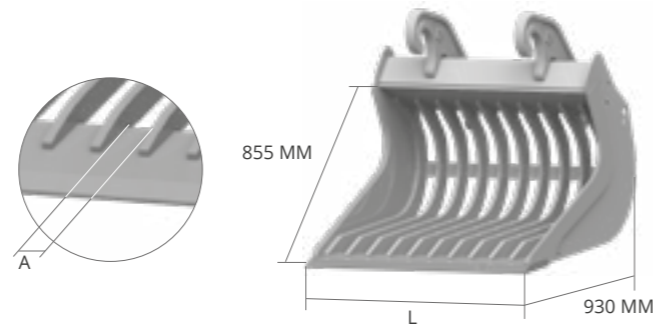

| L MM | A MM | POIDS KG* | CAP. SAE L | |
|---------|---------|--------------|---------------|----|
| 800 | 55 | 159 | 331 | AF |
| 800 | 55 | 159 | 331 | CW |
| 900 | 53 | 172 | 384 | AF |
| 900 | 53 | 172 | 384 | CW |
| 1000 | 55 | 186 | 437 | AF |
| 1000 | 55 | 186 | 437 | CW |
| 1100 | 57 | 204 | 490 | AF |
| 1100 | 57 | 204 | 490 | CW |
| 1200 | 55 | 217 | 542 | AF |
| 1200 | 55 | 217 | 542 | CW |
| 1300 | 57 | 231 | 595 | AF |
| 1300 | 57 | 231 | 595 | CW |

EN OPTION

| 4 | 4 | 5 |
|----------|-----------|-----------------------|
| DENTS DC | DENTS DTE | VERSION RÉVERSIBLE CW |



Sur la Forêt, 16 - 5340 SOREE (Belgique)
+32/83/67.72.33
info@monfortsa.be
www.monfortsa.be

